

# Journal of Experimental Psychology

---

---

VOL. 47, No. 6

JUNE, 1954

---

---

## THE INFORMATION CAPACITY OF THE HUMAN MOTOR SYSTEM IN CONTROLLING THE AMPLITUDE OF MOVEMENT<sup>1</sup>

PAUL M. FITTS<sup>2</sup>

*The Ohio State University*

Information theory has recently been employed to specify more precisely than has hitherto been possible man's capacity in certain sensory, perceptual, and perceptual-motor functions (5, 10, 13, 15, 17, 18). The experiments reported in the present paper extend the theory to the human motor system. The applicability of only the basic concepts, *amount of information, noise, channel capacity, and rate of information transmission*, will be examined at this time. General familiarity with these concepts as formulated by recent writers (4, 11, 20, 22) is assumed.

Strictly speaking, we cannot study man's motor system at the behavioral level in isolation from its associated sensory mechanisms. We can only analyze the behavior of the entire receptor-neural-effector system. How-

ever, by asking *S* to make rapid and uniform responses that have been highly overlearned, and by holding all relevant stimulus conditions constant with the exception of those resulting from *S*'s own movements, we can create an experimental situation in which it is reasonable to assume that performance is limited primarily by the capacity of the motor system. The motor system in the present case is defined as including the visual and proprioceptive feedback loops that permit *S* to monitor his own activity.

The information capacity of the motor system is specified by its ability to produce consistently one class of movement from among several alternative movement classes. The greater the number of alternative classes, the greater is the information capacity of a particular type of response. Since measurable aspects of motor responses, such as their force, direction, and amplitude, are continuous variables, their information capacity is limited only by the amount of statistical variability, or noise, that is characteristic of repeated efforts to produce the same response. The information capacity of the motor system, therefore, can be

<sup>1</sup>This research was supported in part by the United States Air Force under Contract No. AF 33(038)-10528 with the Ohio State University Research Foundation, monitored by the Air Force Personnel and Training Research Center. Permission is granted for reproduction, publication, use, and disposal in whole or in part by or for the United States Government.

<sup>2</sup>Charles Kelly, Robert Silverman, and Charlotte Christner assisted in collecting the data here reported.

inferred from measures of the variability of successive responses that  $S$  attempts to make uniform.

It is possible to determine experimentally the noise associated with each category of response amplitude and rate, and to infer the average information capacity per response and the maximum average rate of information transmission from the ratio of the magnitude of this noise to the magnitude of the possible range of responses. This line of reasoning agrees with Miller's (20) suggestion that the concept of information capacity can be interpreted as a sort of modern version of the traditional Weber-fraction and is consistent with Theorem 17 in Shannon (22).<sup>3</sup>

The present experiments are limited to motor tasks in which  $S$  is asked to make successive responses having a specified amplitude of movement. The information in which we are interested is generated in discrete increments, an increment being added by each successive "response." The relations to be studied are those holding among (a) the average amplitude, (b) the average duration, and (c) the distribution of successive amplitudes (variability) of a series of rapid movements that  $S$  attempts to produce with uniform amplitude. The thesis to be examined is that the channel capacity of the motor system, in a task involving a particular limb, a particular set of muscles, and a particular type of motor behavior (within limits), is independent of average amplitude and

<sup>3</sup>Theorem 17 states that "the capacity of a channel of band  $W$  perturbed by white thermal noise of power  $N$  when the average transmitter power is limited to  $P$  is given by

$$C = W \log \frac{P+N}{N} \quad (22, \text{ p. } 67).$$

$W$  is in cycles per second and takes the form of the reciprocal of some value of time. The power of a band of noise is equivalent to the variance of its amplitude distribution around its mean value.

of specified permissible variability (movement tolerance).

The need for a unifying concept of motor capacity is indicated by the apparent difficulty of reconciling many of the facts reported in the literature on motor skill. These difficulties have in large measure stemmed from failure to recognize that the amplitude, the duration, and the variability of movements are interrelated.

Early investigators were interested chiefly in activities such as running, tapping with a telegraph key, writing long-hand, and keeping time with a baton in which visual monitoring of successive movement is minimal and in which successive movements do not have to be terminated precisely. The duration of this type of movement is essentially independent of its extent. Bryan (2), for example, reported that tapping rate varied only from 4.6 to 6 cps over an amplitude range from 1 to 40 mm. Noting that his results confirmed earlier experiments by Von Kries, he concluded that when movements are made at maximum rate ". . . the rate varies slightly with different muscles; increases with practice; but is not affected by variations of the amplitude of motion within wide limits, a certain medium amplitude requiring less time than longer or shorter distances" (2, p. 138). Freeman (9) studied handwriting movement and found little variation in the total time required to write letters as their size was varied. Stetson and McDill state categorically that "since the duration of the rapid movement is fixed, there can be but two variables, extent and force" (23, p. 25), and Hartson (12) makes fixed duration the basic characteristic of the ballistic movement.

Recent investigators (1, 3, 14, 21), studying tasks that require  $S$  to exercise precise control of movement amplitude but rely on his subjective standard of acceptable movement precision, have reported results that are contrary to those cited in the preceding paragraph. An example of such a task is moving a control quickly so as to realign a spot and

a cross hair on an oscilloscope after the spot is suddenly displaced. Typically  $S$  is instructed to make an "exact" adjustment by the use of vision. The findings for this type of task indicate that the duration of quick corrective movements is a monotonically increasing function of amplitude. Studies of eye movements (6, 24) reveal a similar increase of movement duration with an increase in amplitude.

Although it has been known for many years that the accuracy of quick movements decreases with amplitude, the close relation of speed, amplitude, and accuracy often has been lost sight of. One of the earliest workers to emphasize the importance of their interrelation was Woodworth (25). Studying a variety of simple motor tasks performed with and without visual monitoring, he found that for quick, visually controlled movements variable error increases both with amplitude and with speed. Industrial engineers (19) also have consistently advocated that small-amplitude movements be used whenever possible in assembly work, on the grounds that the time required to complete a unit of work increases as a function of its amplitude as well as of the precision demanded by the task.

The concept of a fixed information-transmission capacity of the motor system not only accounts for such divergent results but also suggests a way of relating quantitatively the amplitude, duration, and variability of motor responses. The concept leads to the expectation that if repetitive movements of a fixed average amplitude are speeded up, then on the average each movement can provide less information, and movement variability will increase by a specified amount. Similarly, it suggests that if average movement amplitude should be increased then variability and/or average duration will also increase. The thesis can be tested experimentally in several ways.

An accepted method for estimating channel capacity in the case of a con-

tinuous signal requires a determination of the average power of the noise associated with the output signal. An experimental determination of the channel capacity of the human motor system by this method would require that the average amplitude and duration (or frequency) of movements be controlled by  $E$  and that the amplitude variability of  $S$ 's movements be measured by procedures similar to those used by Woodworth (25). However, the recording and measurement of successive movement amplitudes are laborious. Fortunately for the present purpose man has remarkably good ability to adjust his average rate of performance to meet the demands of a particular task, such as the requirement that his movements fall within some specified tolerance range. Thus it is possible to assess the tenability of the thesis of fixed information capacity by means of a test of the following specific hypothesis: *If the amplitude and tolerance limits of a task are controlled by  $E$ , and  $S$  is instructed to work at his maximum rate, then the average time per response will be directly proportional to the minimum average amount of information per response demanded by the particular conditions of amplitude and tolerance.*

In performing a given task  $S$  may actually use movements that are less variable, i.e., which generate more information, than the minimum demanded by the task. When only the limits of variability are specified, the minimum information condition is met if all amplitudes within the tolerance range are used equally often, i.e., when responses are distributed rectilinearly over the tolerance range, whereas the actual dispersion of response terminations is an approximate Gaussian distribution. The rate at which  $S$  makes successive responses in a given task, therefore, must be interpreted as the rate at which he can

generate, on the average, at least as much information per response as that demanded by the task. This restriction on the interpretation that can be given to results obtained with the present procedure is more than compensated for by the fact that the procedure makes it feasible to study a wide variety of task conditions with relatively large samples of Ss and responses.

### EXPERIMENT I: RECIPROCAL TAPPING

In the first experiment two closely related reciprocal tapping tasks were studied. The Ss were asked to tap two rectangular metal plates alternately with a stylus. Movement tolerance and amplitude were controlled by fixing the width of the plates and the distance between them. The task was accomplished primarily by movements of the lower arm.

#### Method

*Apparatus and procedure.*—A schematic drawing of the apparatus is shown in Fig. 1. The target plates were 6 in. long and of four different widths (2, 1, .5, and .25 in.). The widths of the plates (hereafter referred to as  $W_s$ ) established the tolerance limits within which movements had to be terminated in amplitude. An additional error plate was mounted on either side of each target plate. The error plates were wide enough to catch all overshoots and undershoots. Six counters, activated by thyatron circuits through the plates and stylus, provided an automatic record of hits, overshoots, and undershoots for each set of three plates. After one of the counters in each group of three had recorded, none of the counters in that group would score again until one of the opposite set of plates had been

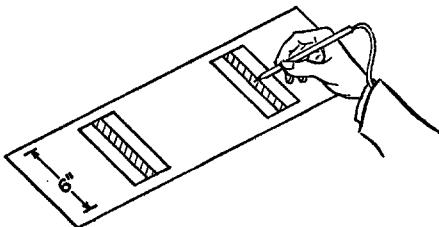

FIG. 1. Reciprocal tapping apparatus. The task was to hit the center plate in each group alternately without touching either side (error) plate.

touched. Thus the first plate touched on either side was always the one scored.

Four center-to-center distances between the target plates were studied (2, 4, 8, and 16 in.) giving a total of 16 combinations of amplitude ( $A$ ) and target size. (For  $A = 2$  in. and  $W_s = 2$  in. no undershoot errors were possible.)

Two metal-tipped styluses were used. One weighed 1 oz. and was about the size of a pencil. The other weighed 1 lb. and was slightly larger. The use of one or the other of these two styluses permitted the amount of work to be varied without otherwise changing the task.

The S sat with his right arm midway between the plates, which were located at a convenient height and angle. Each trial lasted 15 sec. and was followed by a 55-sec. rest period.

The following instructions were read to each S:

"Strike these two target plates alternately. Score as many hits as you can. If you hit either of the side plates an error will be recorded. You will be given a 2-sec. warning before a trial. Place your hand here and start tapping as soon as you hear the buzzer. *Emphasize accuracy rather than speed.* At the end of each trial I shall tell you if you have made any errors."

*Subjects.*—Sixteen right-handed college men served as Ss.

*Sequence of trials.*—Each S was tested at each of the 16 conditions. A different random sequence of conditions was used for each S with the restriction that for the entire group of 16 Ss each condition occur once on each trial. The experiment was replicated on the same day by retesting each S on each condition in a reversed sequence.

Each S participated in the experiment for two days. The lighter stylus was used on the first day, the heavier on the second day. All other procedures on the two days were the same. No attempt was made to equalize practice effects between the lighter and heavier styluses, because  $E$  was interested chiefly in the effects of amplitude and tolerance changes within each variation of the task.

#### Results

The time and error data for the two variations of the tapping task are included in Table 1. The data are expressed as the average time ( $t$ ), in seconds, between taps (i.e., the time for each right-left or left-right movement) and as the percentage of errors (i.e., movements that were either too long or too short). Percentages are based on from 613 to 2,669 movements per condition.

TABLE 1  
TASK CONDITIONS AND PERFORMANCE DATA FOR 16 VARIATIONS OF A  
RECIPROCAL TAPPING TASK

(*N* = the same 16 *Ss* at each condition)

Tolerance and Amplitude Conditions			1-oz. Stylus				1-lb. Stylus			
<i>W<sub>s</sub></i>	<i>A</i>	<i>I<sub>d</sub></i>	<i>t</i>	Errors (%)	<i>I<sub>p</sub></i>	Rank	<i>t</i>	Errors (%)	<i>I<sub>p</sub></i>	Rank
.25	2	4	.392	3.35	10.20	11	.406	3.80	9.85	7
.25	4	5	.484	3.41	10.33	9	.510	3.83	9.80	8
.25	8	6	.580	2.78	10.34	8	.649	4.04	9.24	13
.25	16	7	.731	3.65	9.58	14	.781	4.08	8.96	15
.50	2	3	.281	1.99	10.68	5	.281	0.88	10.68	4
.50	4	4	.372	2.72	10.75	3.5	.370	2.16	10.81	2
.50	8	5	.469	2.05	10.66	6	.485	2.32	10.31	6
.50	16	6	.595	2.73	10.08	12	.641	2.27	9.36	11
1.00	2	2	.212	0.44	9.43	15	.215	0.13	9.30	12
1.00	4	3	.260	1.09	11.54	1	.273	0.85	10.99	1
1.00	8	4	.357	2.38	11.20	2	.373	1.17	10.72	3
1.00	16	5	.481	1.30	10.40	7	.526	1.32	9.50	10
2.00	2	1	.180	0.00	5.56	16	.182	0.00	5.49	16
2.00	4	2	.203	0.08	9.85	13	.219	0.09	9.13	14
2.00	8	3	.279	0.87	10.75	3.5	.284	0.65	10.56	5
2.00	16	4	.388	0.65	10.31	10	.413	1.72	9.68	9

Note.—*W<sub>s</sub>* is the width in inches of the target plate. *A* is the distance in inches between the centers of the two plates. *t* is the average time in seconds for a movement from one plate to the other. The performance index, *I<sub>p</sub>*, is discussed in the text.

The average number of errors made in this task was small, only 1.2% with the lighter stylus and 1.3% with the heavier one. The low incidence of errors indicates that *Ss* successfully adjusted their rate of performance to meet changed task conditions.

The largest proportion of errors, 3.6% with the lighter stylus and 4.1% with the heavier stylus, was made at the most difficult task condition ( $W_s = \frac{1}{4}$  in., *A* = 16 in.). At each amplitude step the percentage of errors for more exacting tolerances was consistently slightly larger than for less exacting tolerances; this indicated that *Ss* did not slow down their movements quite as much as necessary to effect the required accuracy at the more exacting conditions. Nor were the errors symmetrically distributed over the error plates. The *Ss* were uniformly more accurate in terminating flexor than extensor movements. With the lighter stylus over- and undershoot errors were equally frequent, but with the heavier stylus

undershoots were about twice as frequent. However, in spite of such consistent trends, the relatively small incidence of errors justifies an analysis of the data in terms of the total number of movements made under the various task conditions.

Practice led to relatively small improvement in performance. The mean time per movement for all *Ss* and all task conditions decreased by 3% from the first to the second block of trials with the light stylus, and by 5% with the 1-lb. stylus. The total number of errors made by all *Ss* was almost exactly the same for the first as for the second block of trials.

For each category of *W<sub>s</sub>*, movement time increased progressively as movement amplitude (*A*) increased. Likewise for each amplitude, movement time increased progressively as tolerance was decreased. The relations among the various conditions for the lighter and heavier styluses were similar.

EXPERIMENT II: DISC TRANSFER

The second task was to transfer plastic washers from one pin to another. Again, the amplitude and tolerance of the positioning movements were varied through a series of geometric steps, and the rate of performance was measured. This task differed from the previous one in that no errors were permitted. Some amount of finger activity was involved in grasping a washer by the edges before removing it from the pin.

Method

*Apparatus and procedure.*—A schematic drawing of the apparatus is shown in Fig. 2. Round plastic discs,  $\frac{1}{8}$  in. thick and 1.5 in. in diameter, were drilled with four sizes of holes. Eight discs of uniform size were placed over a  $\frac{1}{8}$ -in. pin. The task was to transfer the discs, one at a time, to another pin. The transfer of eight discs constituted a trial.

The difference between the diameter of the pins and the diameter of the center hole of the discs was varied in four geometric steps ( $\frac{1}{8}$ ,  $\frac{1}{4}$ ,  $\frac{1}{2}$ , and  $\frac{3}{8}$  in.). Four amplitudes of movement (4, 8, 16, and 32 in.) were used, making a total of 16 conditions. The S touched a switch plate beside the empty pin as he began the task. This started a 1/100-sec. timer. The S touched the switch plate as soon as he had transferred the last disc. This stopped the timer. Discs were always moved from right to left.

*Subjects.*—Sixteen right-handed college men served as Ss. They were different Ss from those used in Exp. I.

*Sequence of trials.*—Each S worked at all 16 task conditions in a restricted randomized sequence corresponding to that used in the previ-

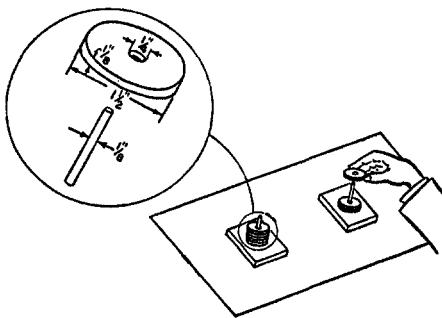

FIG. 2. Disc transfer apparatus. The task was to transfer eight washers one at a time from the right to the left pin. The inset gives the dimensions for the  $W_s = \frac{1}{8}$  in. condition.

ous experiment. The entire procedure was then replicated on a second day using a different sequence of trials for each S.

Results

The transfer of a disc involves a transport-empty plus a transport-loaded movement, and the times given are an average of these two aspects of each transfer cycle. There was a small (6%) decrease in time per movement on the second set of 16 trials. The average times per movement for each condition, averaged over all 16 Ss and over both days, are given in Table 2 in the column labeled  $t$ . The variations in movement time with increase in movement amplitude and changes in tolerance correspond to those found in Exp. I.

EXPERIMENT III: PIN TRANSFER

The third task was to transfer pins from one set of holes to another. Grasping and releasing movements of the fingers were required in addition

TABLE 2  
TASK CONDITIONS AND PERFORMANCE DATA  
FOR 16 VARIATIONS OF A  
DISC-TRANSFER TASK

( $N =$  the same 16 Ss at each condition)

Tolerance and Amplitude Conditions			Performance		
$W_s$	$A$	$I_d$	$t$	$I_p$	Rank
.0625	4	7	.697	10.04	2.5
.0625	8	8	.771	10.38	1
.0625	16	9	.896	10.04 $\frac{1}{2}$	2.5
.0625	32	10	1.096	9.12	7
.125	4	6	.649	9.24	6
.125	8	7	.734	9.54	4
.125	16	8	.844	9.48	5
.125	32	9	1.028	8.75	10
.25	4	5	.607	8.24 $\frac{1}{2}$	12
.25	8	6	.672	8.93	9
.25	16	7	.771	9.08 $\frac{1}{2}$	8
.25	32	8	.975	8.20 $\frac{1}{2}$	13
.5	4	4	.535	7.47 $\frac{1}{2}$	16
.5	8	5	.623	8.02	14
.5	16	6	.724	8.29	11
.5	32	7	.902	7.76	15

Note.— $W_s$  is the difference in inches between the diameter of the post and the diameter of the center hole of the disc.  $A$  is the center-to-center distance between the two posts.  $t$  is the average time in seconds for a movement between two posts.

to arm movements. No errors were permitted. The task was varied in four geometric steps of movement tolerance and in five geometric steps of amplitude. The time for completing a series of eight responses was recorded. The data for this task are somewhat more extensive, and somewhat more practice was given on this task than in the two preceding experiments.

### Method

*Apparatus and procedure.*—The pin-transfer apparatus is shown in Fig. 3. Four sizes of pins ( $\frac{1}{8}$ ,  $\frac{1}{16}$ ,  $\frac{1}{32}$ , and  $\frac{1}{64}$  in. in diameter) and five amplitudes of movement (1, 2, 4, 8, and 16 in.) were employed, thus making a total of 20 task conditions. Each set of pins was used with a set of holes whose diameter was twice that of the pins. The difference between the two diameters determined the tolerance ( $W_s$ ) required in transferring a pin from one hole to another. The tips of the pins were tapered to one-half their diameter as shown in the inset of Fig. 3.

The S started and stopped a timer as in the preceding task, in order to record the over-all time for making eight transport-empty plus eight transport-loaded movements. A trial consisted of the transfer of eight pins from one side to the other followed after a short rest by the transfer of the same pins in the opposite direction.

The instructions were similar to those employed in the preceding experiments.

*Subjects.*—Twenty college students, ten men and ten women, served as Ss. These were different Ss from those serving in Exp. I and II.

*Sequence of trials.*—Each S served under all task conditions. The sequence of conditions was randomized, with the restriction that for the group of 20 Ss each condition occur once on each trial and once for each S. The experiment was repeated three times with the same Ss on three separate days. The sequence of trials for each S was different each day.

### Results

There was some improvement in the rate of task performance from the first to the second day, but little further improvement on the third day. The over-all means for the three days were .613, .585, and .578 sec. per movement, respectively. The average movement times computed for the combined trials of the second and third replications of the experiment are given in Table 3 in the column labeled  $t$ . The relations

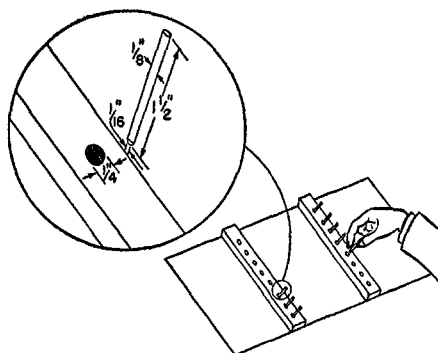

FIG. 3. Pin transfer apparatus. The task was to transfer eight pins one at a time from one set of holes to the other. The inset gives the dimensions of pins and holes for the  $W_s = \frac{1}{16}$  in. condition.

among the data correspond closely to those found in the previous experiments. Movement times increased progressively as the tolerance requirement was made more stringent and as amplitude was increased.

### INFORMATION ANALYSIS

The rate of performance of all the tasks studied increased uniformly as movement amplitude was decreased and as tolerance limits were extended. These results agree qualitatively with the predictions from the hypothesis.

In order to test the results against a quantitative prediction that the information output of the human motor system in any particular type of task is relatively constant over a range of amplitude and accuracy requirements, a difficulty index is needed that will specify the minimum information required on the average for controlling or organizing each movement.

The rational basis for this estimate of task difficulty is the maximum relative uncertainty that can be tolerated for a "correct" movement in a series having a specified average amplitude.<sup>4</sup> Thus the minimum organization re-

<sup>4</sup> Although only amplitude is considered here, the present rationale can be extended to the question of the rate of information involved in the selection of the direction, the force, or the duration of movements.

TABLE 3  
TASK CONDITIONS AND PERFORMANCE DATA  
FOR 20 VARIATIONS OF A PIN-  
TRANSFER TASK  
( $N =$  the same 20 Ss at each condition)

Tolerance and Amplitude Conditions			Performance		
$W_s$	$A$	$I_d$	$t$	$I_p$	Rank
.03125	1	6	.673	8.92	20
.03125	2	7	.705	9.93	18
.03125	4	8	.766	10.44	14
.03125	8	9	.825	10.91	13
.03125	16	10	.959	10.43	15
.0625	1	5	.484	10.33	16
.0625	2	6	.518	11.58	11
.0625	4	7	.580	12.07	6
.0625	8	8	.644	12.42	2
.0625	16	9	.768	11.72	9
.125	1	4	.388	10.31	17
.125	2	5	.431	11.60	10
.125	4	6	.496	12.10	5
.125	8	7	.557	12.57	1
.125	16	8	.668	11.98	7
.25	1	3	.326	9.20	19
.25	2	4	.357	11.20	12
.25	4	5	.411	12.16	4
.25	8	6	.486	12.34	3
.25	16	7	.592	11.82	8

Note.— $W_s$  is the difference in inches between the diameter of the pins and the diameter of the hole into which they were inserted.  $A$  is the center-to-center distance between the holes.  $t$  is the average time in seconds for a single movement.

quired of a particular movement is defined by the specification of one from among  $k$  possible categories of amplitude within which the movement is to terminate.

If we follow the above reasoning and conventional information notation, a binary index of difficulty ( $I_d$ ) is defined as

$$I_d = -\log_2 \frac{W_s}{2A} \text{ bits/response, (1)}$$

where  $W_s$  is the tolerance range in inches and  $A$  is the average amplitude of the particular class of movements. The choice of the denominator for this index is arbitrary since the range of possible amplitudes must be inferred. The use of  $2A$  rather than  $A$  is indicated by both logical and practical considerations. Its use insures that the index will be greater than zero for all practical situations and has the

effect of adding one bit ( $-\log_2 \frac{1}{2}$ ) per response to the difficulty index. The use of  $2A$  makes the index correspond rationally to the number of successive fractionations required to specify the tolerance range out of a total range extending from the point of initiation of a movement to a point equidistant on the opposite side of the target.

The index of difficulty ( $I_d$ ) is given in Tables 1, 2, and 3 for each of the tasks. Since the index takes into account only the information necessary to specify the amplitude of a movement, it is insensitive to the weight of the stylus used in the first experiment and hence to the physical work required by the task. In its present form, the index is also insensitive to the information required for specifying the direction of a movement, or for specifying additional manipulatory acts such as the finger movements required to grasp and release objects.

Also shown in Tables 1, 2, and 3 is a binary index of performance ( $I_p$ ), which expresses the results as a performance rate. For a task in which  $W_s$  and  $A$  are fixed for a series of movements,  $I_p$  is defined as

$$I_p = -\frac{1}{t} \log_2 \frac{W_s}{2A} \text{ bits/sec., (2)}$$

where  $t$  is the average time in seconds per movement. This index has some resemblance to one by Goldman (11, p. 157, Formula 29) for maximum information rate, although Goldman's criterion for determining the number of possible categories is based on a mean square criterion.

We want to test the hypothesis that movement time varies with task difficulty in such a way that  $I_p$  is constant over a wide range of movement amplitudes and tolerances. It is apparent from the data in Tables 1, 2, and 3 that even though the index is not precisely constant, the hypothesis is substantially confirmed.

For the eight best (out of the 16)



conditions of tapping with the light weight stylus, the rate of performance varied between 10.3 and 11.5 bits/sec., a range of only 1.2 bits. Performance fell off markedly only for the least exacting bits/sec., condition studied ( $A = 2$  in.,  $W_s = 2$  in.).

Performance rate with the 1-lb. stylus also was relatively stable over a comparable range of amplitudes and tolerances. The rate at all but two conditions was reduced slightly by the added work, and the region of maximum performance was shifted toward smaller amplitudes of movement. The Pearsonian correlation between the 16  $I_p$  values for the two variations in the tapping task was large however ( $r = .97$ ).

For the 16 conditions of the disc-transfer task, on which the difficulty index ranged from 4 to 10 bits/response, the rate of performance varied from 7.5 to 10.4 bits/sec. Over the eight best conditions the range was only 1.3 bits/sec.

Performance on the pin-transfer task varied from 8.9 to 12.6 bits/sec. for the 20 conditions studied, but the range of variability was only 1.0 bit/sec. over the ten best conditions.

In all tasks it was found that movement amplitudes and tolerances could be varied within limits without much effect on performance rate, but that performance began to fall off outside these limits. This is readily apparent from an inspection of Fig. 4, which is a three-dimensional representation of the performance data for the pin-transfer task. Movements of 1- and 2-in. amplitude were consistently less efficient than movements of 4 to 8 in. In the pin-transfer task in particular, both the smallest amplitude (1 in.) and the smallest tolerance ( $1/32$  in.) resulted in relatively low rates of performance. In most cases performance rate also fell off at the largest amplitudes and tolerances. Throughout all the tasks, movement amplitudes of 4

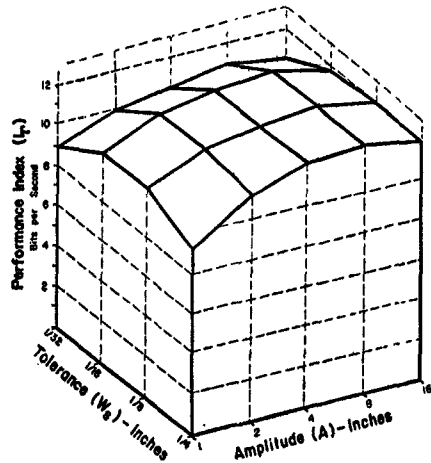

FIG. 4. Three-dimensional representation of performance rate ( $I_p$ ) in bits per second for the pin-transfer task as a function of amplitude and tolerance requirements

to 8 in. were more consistently associated with good performance than was any particular tolerance or any particular difficulty index.

#### DISCUSSION

Although the four tasks thus far analyzed are a small sample of perceptual-motor activities, the results are sufficiently uniform to indicate that the hypothesized relation between speed, amplitude, and tolerance may be a general one. It is not surprising to find that performance, measured in information units, is relatively constant over a central range of amplitude and accuracy conditions and falls off outside these limits. Such a relation holds for most perceptual and motor activities and has recently been found (16) in a study of the optimum relation between the amplitude of lever movement and observed display movement.

The absolute level of capacity of the motor system probably varies considerably for different movements, limbs, and muscle groups. For example, the arm, which in the present experiments was asked to generate information only in respect to successive movement amplitudes, may have a lower information capacity than the hand. Using all of his fingers singly and in combinations,  $S$  can produce one bit of information per re-

sponse per finger. Quite likely he can sustain higher level performance by using finger rather than arm movements. More complex movement patterns than those studied may also have a higher information capacity since in this case information can be generated along several dimensions simultaneously.

The estimates of information capacity arrived at by the present procedures give lower values than would be obtained by other and perhaps equally tenable assumptions regarding the number of possible categories. However, the estimates are of similar magnitude, in fact slightly higher, than the figures reported for the average  $S$  in a perceptual-motor task, such as pressing keys in response to flashing lights (18), in which responses to a series of discrete stimuli have been studied.

The present index of difficulty can be applied to a wide range of motor tasks. For example the three stick and rudder control movements necessary to make a single match on the Complex Coordination Test (Model E) require one bit of information to specify each of the three directions of movement and 3.9 bits to specify each of the three amplitudes (a total of 14.7 bits); this assumes that  $S$  starts his adjustments with the controls in the neutral position.

Ellson (7) has raised the question of the linearity of motor responses, using the superposition theorem as the criterion of linearity. This theorem demands that movement duration remain constant as amplitude increases. We have noted that many recent data violate this requirement. However, the present results indicate that over the range in which performance is optimum, movements of differing amplitude but of equal difficulty in terms of information tend to be of approximately equal duration. Man differs from a linear electronic or mechanical system, however, in that he sometimes varies his standard of relative precision for a movement at the same time as he varies its amplitude; unless relative precision remains constant, movement time will vary with amplitude.

The basis for the uniformity of motor performance perhaps is to be found in the time taken for central organizing proc-

esses. Fenn has pointed out that in reciprocal movements made at maximum rate and without any visual control the muscles work at a level far below their physical capacity. Since maximum rate of performance in this case is not limited by the muscles, he has proposed that the maximum rate is limited by ". . . the speed with which excitation and inhibition can be made to alternate in the central nervous system without at the same time losing precise control of the magnitude of the force" (8, p. 174). This concept of central organizing time is entirely consistent with an information point of view. The finding that relatively small differences in performance result from the change in stylus weight, and the validity of predictions of performance rate from the index of task difficulty lend support to the basic thesis of this paper, that it is the degree of control required over the organization of a response, i.e., the amount of information required to specify a response, which is the major factor limiting the rate of motor performance.

#### SUMMARY

The present paper attempts to relate the traditional Weber function (variability of a response as a function of its amplitude) to the parallel phenomena of variability as a function of response duration, using certain concepts of information theory.

An index of the difficulty of a movement is proposed on the assumption that the average amplitude, the average duration, and the amplitude variability of successive movements are related in a manner suggested by information theory. The basic rationale is that the minimum amount of information required to produce a movement having a particular average amplitude plus or minus a specified tolerance (variable error) is proportional to the logarithm of the ratio of the tolerance to the possible amplitude range. The specification of the possible amplitude range is arbitrary and has been set at twice the average amplitude. The average rate of information generated by a series of movements is the average information per movement divided by the time per movement.

Three experiments are reported which were designed to test the following hypothesis: If the amplitude and tolerance limits of a task are fixed and the  $S$  is instructed to work at his maximum rate, then the average duration of responses will be directly proportional to the minimum average amount of information per response (i.e., the

degree of behavior organization) demanded by the task conditions. The conditions studied covered the range from 1 to 10 bits/response.

The results indicate that rate of performance in a given type of task is approximately constant over a considerable range of movement amplitudes and tolerance limits, but falls off outside this optimum range. The level of optimum performance was found to vary slightly among the three tasks in the range between about 10 to 12 bits/sec. The consistency of these results supports the basic thesis that the performance capacity of the human motor system plus its associated visual and proprioceptive feedback mechanisms, when measured in information units, is relatively constant over a considerable range of task conditions. This thesis offers a plausible way of accounting for what otherwise appear to be conflicting data on the durations of different types of movements.

The author feels that the fixed information-handling capacity of the motor system probably reflects a fixed capacity of central mechanisms for monitoring the results of the ongoing motor activity while at the same time maintaining the necessary degree of organization with respect to the magnitude and timing of successive movements.

#### REFERENCES

1. BROWN, J. S., & SLATER-HAMMEL, A. T. Discrete movements in the horizontal plane as a function of their length and direction. *J. exp. Psychol.*, 1949, **39**, 84-95.
2. BRYAN, W. L. On the development of voluntary motor ability. *Amer. J. Psychol.*, 1892, **5**, 125-204.
3. CRAIG, D. R. *Effect of amplitude range on duration of responses to step function displacements*. Dayton, O.: U. S. Air Force, Air Materiel Command, Wright-Patterson Air Force Base, 1949. (AF Tech. Rep. No. 5913.)
4. CRONBACH, L. J. *A consideration of information theory and utility theory as tools for psychometric problems*. Urbana, Ill.: Bureau of Research and Service, Univ. of Illinois, 1953.
5. CROSSMAN, E. R. F. W. Entropy and choice time: the effect of frequency unbalance on choice-responses. *Quart. J. exp. Psychol.*, 1953, **5**, 41-51.
6. DODGE, R., & CLINE, T. S. The angle velocity of eye movements. *Psychol. Rev.*, 1901, **8**, 145-157.
7. ELLSON, D. G. The application of operational analysis to human motor behavior. *Psychol. Rev.*, 1949, **56**, 9-17.
8. FENN, W. O. Mechanics of muscular contraction in man. *J. appl. Physics*, 1938, **9**, 165-177.
9. FREEMAN, F. N. Experimental analysis of the writing movement. *Psychol. Monogr.*, 1914, **17**, No. 4 (Whole No. 75), 1-46.
10. GARNER, W. R., & HAKE, H. W. The amount of information in absolute judgments. *Psychol. Rev.*, 1951, **58**, 446-459.
11. GOLDMAN, S. *Information theory*. New York: Prentice-Hall, 1953.
12. HARTSON, L. D. Contrasting approaches to the analysis of skilled movements. *J. gen. Psychol.*, 1939, **20**, 263-293.
13. HICK, W. E. On the rate of gain of information. *Quart. J. exp. Psychol.*, 1952, **4**, 11-26.
14. HICK, W. E., & BATES, J. A. V. *The human operator of control mechanisms*. London: Ministry of Supply, 1950.
15. HOWES, D. H., & SOLOMON, R. L. Visual duration threshold as a function of word-probability. *J. exp. Psychol.*, 1951, **41**, 401-410.
16. JENKINS, W. L., & OLSON, M. W. The use of levers in making settings on a linear scale. *J. appl. Psychol.*, 1952, **36**, 269-271.
17. KLEMMER, E. T., & FRICK, F. C. Assimilation of information from dot and matrix patterns. *J. exp. Psychol.*, 1953, **45**, 15-19.
18. KLEMMER, E. T., & MULLER, P. F., JR. The rate of handling information. Key pressing responses to light patterns. *USAF Hum. Fact. Operat. Res. Lab.*, 1953, Rep. No. 34.
19. MAYNARD, H. B., STEGEMERTEN, G. J., & SCHWAB, J. L. *Methods—time measurement*. New York: McGraw-Hill, 1948.
20. MILLER, G. A. What is information measurement? *Amer. Psychologist*, 1953, **8**, 3-11.
21. SEARLE, L. V., & TAYLOR, F. V. Studies in tracking behavior. I. Rate and time characteristics of simple corrective movements. *J. exp. Psychol.*, 1948, **38**, 615-631.
22. SHANNON, C., & WEAVER, W. *The mathematical theory of communication*. Urbana: Univ. of Illinois Press, 1949.
23. STETSON, R. H., & McDILL, J. A. Mechanism of the different types of movement. *Psychol. Monogr.*, 1923, **32**, No. 3 (Whole No. 145), 18-40.
24. WESTHEIMER, G. The response of the oculomotor system to visual stimuli in the horizontal plane. Unpublished doctor's dissertation, Ohio State Univ., 1953.
25. WOODWORTH, R. S. The accuracy of voluntary movement. *Psychol. Monogr.*, 1899, **3**, No. 2 (Whole No. 13).

(Received for early publication March 13, 1954)